	TECHNICAL SPECIFICATION		N I-ET-3000.00-5529-850-PEK-007								
	CLIENT	PETROBRAS						SHEET	1	of	47
	JOB	RIGID RISER SYSTEMS									
SUB	AREA	—							PUBLIC		
	TITLE	RIGID RISER MONITORING SYSTEM (RRMS) – RISER SCOPE – HULLSIDE UMBILICAL SOLUTION							SUB/ES/EECE/ECE		
REVISION INDEX											
REV.	DESCRIPTION AND/OR REVISED SHEETS										
0	Original										
A	Revisions marked in yellow.										
	REV. 0	REV. A	REV. B	REV. C	REV. D	REV. E	REV. F	REV. G	REV. H		
DATE	29/10/2021	02/08/2023									
DESIGN	ECE	EECE/ECE									
EXECUTION	BYE8	BYE8									
CHECK	Y5UJ	DVHV / B8WL									
APPROVAL	UR6A	CXF0									
THE INFORMATION CONTAINED IN THIS DOCUMENT IS PETROBRAS PROPERTY AND MAY NOT BE USED FOR PURPOSES OTHER THAN THOSE SPECIFICALLY INDICATED HEREIN.											
THIS FORM IS PART OF PETROBRAS N-0381 REV. L											

**TABLE OF CONTENTS**

1	INTRODUCTION	3
1.1	RISER SYSTEMS.....	3
2	ABBREVIATION	4
3	REFERENCE DOCUMENTS, CODES AND STANDARDS	5
3.1	INTERNATIONAL STANDARDS.....	5
3.2	PETROBRAS DOCUMENTS	5
4	DEFINITIONS	6
5	TECHNICAL CHARACTERISTICS	6
5.1	DESIGN AND FABRICATION	6
5.2	QUALIFICATION	7
6	TECHNICAL REQUIREMENTS	8
6.1	SYSTEM OVERVIEW.....	8
6.2	GENERAL REQUIREMENTS.....	9
6.3	TOP INCLINATION MEASUREMENT	10
6.4	TOP STRAIN MEASUREMENT	12
6.5	SUBSEA CABLING	16
6.6	GENERAL REQUIREMENTS OF TOPSIDE PROCESSING SYSTEM	19
6.7	RISER DATA COLLECTION SYSTEM (RDCCS)	20
6.8	SUPERVISORY AND DATA SERVER.....	22
6.9	RRMS CABINET AND EQUIPMENT	25
6.10	CONNECTION ARCHITECTURE	27
6.11	FPU INFRA STRUCTURE SCOPE.....	28
7	TESTS, COMMISSIONING REQUIREMENTS AND ASSISTED OPERATION	31
7.1	QUALIFICATION TESTING.....	31
7.2	FACTORY ACCEPTANCE TESTING	31
7.3	SYSTEM INTEGRATION TESTING.....	31
7.4	INSTALLATION AND COMMISSIONING REQUIREMENTS	32
7.5	DIVING INSTALATION.....	33
7.6	ASSISTED OPERATION.....	33
8	DOCUMENTATION REQUIREMENTS	34
9	TRAINING REQUIREMENTS.....	35
10	SCOPE OF SUPPLY & WORK	36
10.1	GENERAL TOPOLOGY	36
10.2	RISER CONTRACTOR	38
10.3	FPU CONTRACTOR	39
10.4	DIVING TEAM	39
	Annex A: OPC Interface Requirements.....	40
	Annex B: Rigid Riser Top Angles Calculation	41
	Annex C: Rigid Riser Stress Calculation Algorithm.....	43

1 INTRODUCTION

This document presents the Technical Specification of the RISER CONTRACTOR scope of an integrity monitoring system applicable for rigid steel risers in FPU using hull side umbilical solution.

1.1 RISER SYSTEMS

This informative section presents an overview of the riser configurations covered by this monitoring system specification.

1.1.1 Steel Lazy Wave Riser (SLWR)

A Steel Lazy Wave Riser (SLWR) consists of a steel riser with an intermediary section lifted by buoyancy modules. An illustration is presented in figure 1

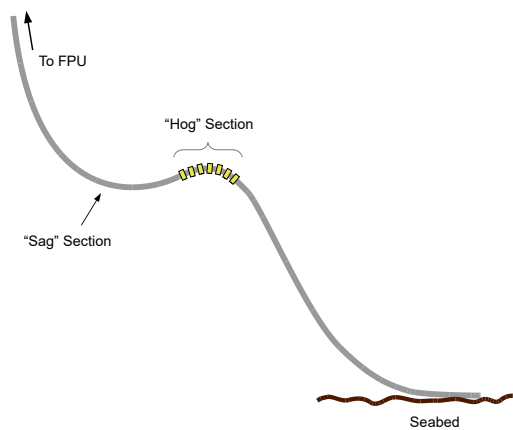

Figure 1 — SLWR illustration

1.1.2 Steel Catenary Riser (SCR)

A Steel Catenary Riser (SCR) is a steel riser that hangs from the FPU in a free single-catenary configuration. This concept is illustrated in figure 2.

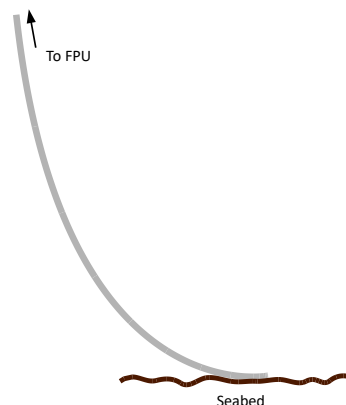

Figure 2 — SCR illustration

2 ABBREVIATION

AC	Alternating Current
AFM	Material Supply Authorization
AHRS	Attitude and Heading Reference System
DC	Direct Current
DMZ	Demilitarized Zone
EFL	Electrical Flying Lead
FAT	Factory Acceptance Test
FBG	Fiber Bragg Grating
FO	Fiber Optic
FPSO	Floating Production, Storage and Offloading
FPU	Floating Production Unit
FXJ	Flexible Joint
GPS	Global Positioning System
IMU	Inertial Measurement Unit
I/O	Input/Output
IP	Ingress Protection
JB	Junction Box
OIL	Optical Insertion Loss
OPC	Open Platform Communications (from OPC Foundation)
OPC UA	OPC Unified Architecture
ORL	Optical Return Loss
PBOF	Pressure Balanced Oil-Filled
PDU	Power Distribution Unit
POS	FPU Positioning System
PSU	Power Supply Unit
PVT	Performance Verification Test
RDCS	Riser Data Collection System
RRMS	Rigid Riser Monitoring System
ROV	Remotely-Operated Vehicle
SCR	Steel Catenary Riser
SIT	System Integration Test
SLWR	Steel Lazy Wave Riser
STK	Sensors Test Kit
TSP	Twisted Shielded Pairs
UPS	Uninterruptible Power Supply
USB	Universal Serial Bus

3 REFERENCE DOCUMENTS, CODES AND STANDARDS

This section lists standards and external documents applicable to the design of the monitoring system.

3.1 INTERNATIONAL STANDARDS

[1] API 17F	<i>Standard for Subsea Production Control Systems</i>
[2] API 17Q	<i>Recommended Practice on Subsea Equipment Qualification</i>
[3] API 17H	<i>Remotely Operated Tools and Interfaces on Subsea Production Systems</i>
[4] ASTM E74 (latest revision)	<i>Standard Practice of Calibration of Force-Measuring Instruments for Verifying the Force Indication of Testing Machines</i>
[5] ASTM A320:2015	<i>Standard Specification for Alloy-Steel and Stainless Steel Bolting for Low-Temperature Service</i>
[6] DNVGL-RP-B401:2017	<i>Cathodic Protection Design</i>
[7] IEC 60079 (latest revision)	<i>Series Explosive Atmosphere Standards</i>
[8] IEC 60092 (latest revision)	<i>Electrical installations in ships - ALL PARTS</i>
[9] IEC 60502-1 (latest revision)	<i>Power cables with extruded insulation and their accessories for rated voltages from 1 kV ($U_m = 1,2$ kV) up to 30 kV ($U_m = 36$ kV) – Part 1: Cables for rated voltages of 1 kV ($U_m = 1,2$ kV) and 3 kV ($U_m = 3,6$ kV);</i>
[10] IEC 60529 (latest revision)	<i>Degrees of Protection Provided by Enclosures (IP Code)</i>
[11] IEC 61892-6	<i>Mobile and fixed offshore units – Electrical installations – Part 6: Installation</i>
[12] ISO 13628-6:2006	<i>Design and Operation of Subsea Production Systems – Subsea Production Systems</i>
[13] NMEA 0183 V 4.10	<i>Standard for Interfacing Marine Electronics Devices</i>

3.2 PETROBRAS DOCUMENTS

[14] I-ET-3010.00-1300-850-PEK-002	<i>HULLSIDE UMBILICAL FOR RISER SYSTEMS</i>
[15] I-ET-3000.00-1500-823-PEK-001	<i>Qualification of Wet-Mate Electrical Connectors and Accessories</i>
[16] N-0858	<i>Construção, Montagem e Condicionamento de Instrumentação</i>
[17] N-0381	<i>Execution of Drawing and Other General Technical Documents</i>
[18] N-1710	<i>Codificação de Documentos Técnicos de Engenharia</i>
[19] I-ET-0000.00-0000-210-P9U-001	<i>PIPELINE FIELD JOINT COATING AND FIELD REPAIR OF LINEPIPE COATING</i>
[20] I-ET-0000.00-0000-431-P9U-001	<i>WET THERMAL INSULATION FOR FLOWLINES AND RISERS</i>
[21] I-ET-0000.00-0000-250-P9U-002	<i>MINIMUM REQUIREMENTS FOR BUOYANCY MODULES FOR FLOWLINES AND SLWRS</i>

4 DEFINITIONS

RISER CONTRACTOR	<i>The company contracted by PETROBRAS to design, supply and install the risers, including the monitoring system (focus of this technical specification)</i>
FPU CONTRACTOR	<i>The company contracted by PETROBRAS to construct the Floating Production Unit</i>
DIVING TEAM	<i>The party responsible for execution of diving-related tasks, to be defined during the bidding phase.</i>
SUPPLIER	<i>Company hired by RISER CONTRACTOR, to supply components from RRMS MONITORING SYSTEM.</i>
MAY	<i>Is used when alternatives are equally acceptable</i>
SHOULD	<i>Is used when a provision is not mandatory, but is recommended as a good practice</i>
SHALL	<i>Is used when a provision is mandatory</i>
WET-MATE [CONNECTOR]	<i>Connector designed for plugging/mating in underwater environments</i>
COVERAGE INTERVAL	<i>Interval containing the set of true values of a measured quantity with a stated probability, based on the information available</i>
COVERAGE PROBABILITY	<i>Probability that the set of true values of a measured quantity is contained within a specified COVERAGE INTERVAL</i>

5 TECHNICAL CHARACTERISTICS

5.1 DESIGN AND FABRICATION

- 5.1.1 All subsea equipment shall be designed in accordance with API 17F [1].
- 5.1.2 Selection of materials for all subsea structures shall be in accordance with DNVGL-RP-B401:2017 [6] item 5.5 and be designed for the same design life as the riser.
- 5.1.3 All enclosures and equipment to be placed in hazardous areas shall comply and be certificated according to IEC 60079 [7]
- 5.1.4 All enclosures with a required degree of ingress protection shall comply with IEC 60529 [10]
- 5.1.5 Electrical and communication analyses shall be performed, including simulations considering the parameters of specified cable types (for deck, hull and subsea cables).



TECHNICAL SPECIFICATION

Nº

I-ET-3000.00-5529-850-PEK-007

REV.

A

JOB

RIGID RISER SYSTEMS

SHEET

7

of

47

TITLE

**RIGID RISER MONITORING SYSTEM (RRMS) –
RISER SCOPE – HULLSIDE UMBILICAL SOLUTION**

5.2 QUALIFICATION

5.2.1 All subsea equipment shall be qualified in accordance with API 17Q [2] or ISO 13628-6:2006 [12].

6 TECHNICAL REQUIREMENTS

6.1 SYSTEM OVERVIEW

6.1.1 Figure 3 presents a general diagram of the riser monitoring system.

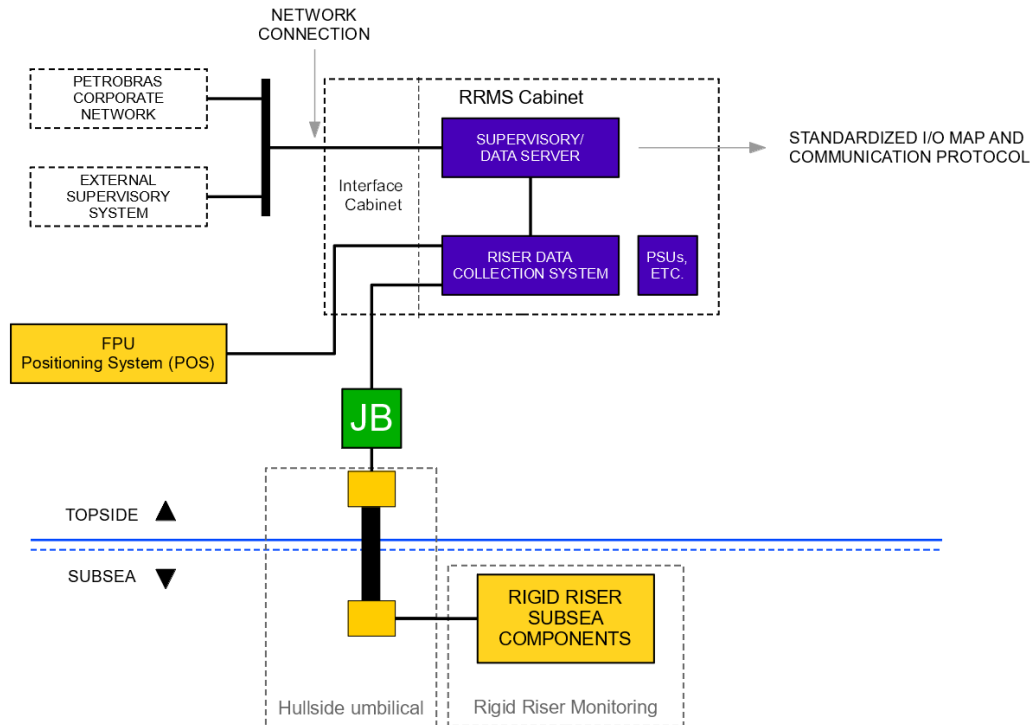

Figure 3 — General system diagram

6.1.2 The system is composed of a topside processing system which communicates with sensors and equipment installed on subsea riser structures and FPU Positioning System (POS).

6.1.3 The base case for the design of the subsea components shall be for shallow water (minimum depth of 100 m and maximum depth design according to the pipelay requirements during pull-in operation). In the case of the Wet Storage scenario of the rigid lines, the subsea components shall be designed for the project's water depth.

6.2 GENERAL REQUIREMENTS

- 6.2.1** Design life of the subsea components shall be the same of the riser, unless otherwise specified.
- 6.2.2** The purpose of rigid riser monitoring is to assess fatigue life consumption due to cyclic loading.
- 6.2.3** The Figure 4 presents an overview of general topology of the system.

Note: FPU CONTRACTOR shall provide space for 2 RRMS Cabinets, however RISER CONTRACTOR initial design shall be a solution with 1 cabinet supply, the second space can be used if RISER CONTRACTOR informs that needs 2 cabinets for its final solution or for a second phase of rigid risers contract with another contractor. **This shall be subjected to PETROBRAS approval.**

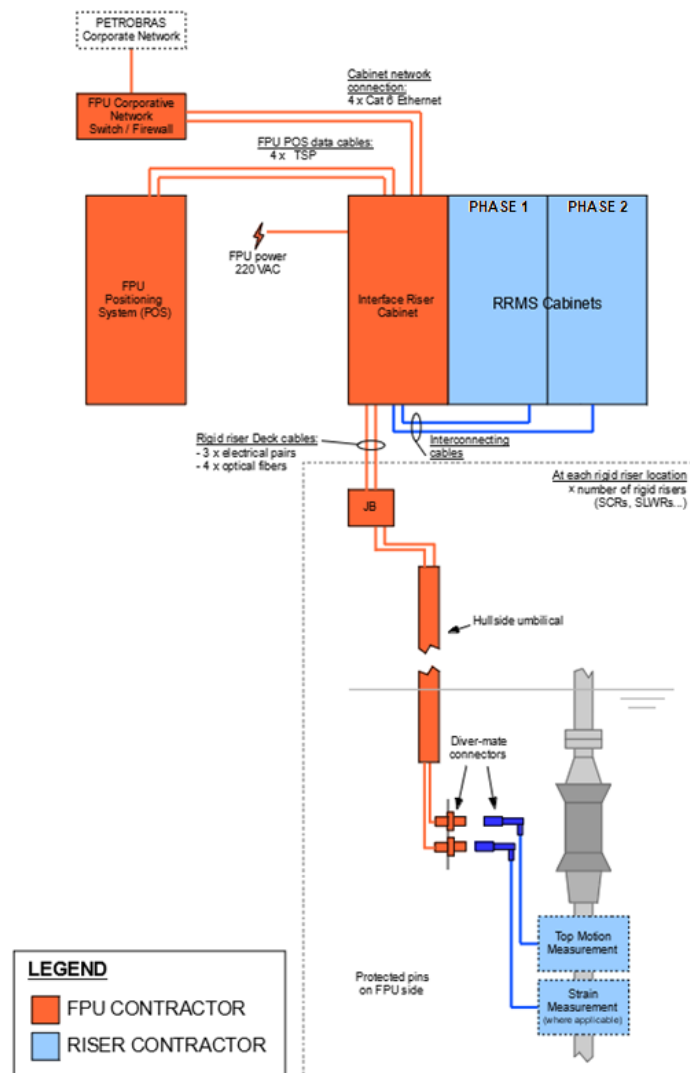



Figure 4 — General topology – RRMS System (for Phases 1 and 2)

	TECHNICAL SPECIFICATION	Nº I-ET-3000.00-5529-850-PEK-007	REV. A
	JOB	RIGID RISER SYSTEMS	SHEET 10 of 47
	TITLE	RIGID RISER MONITORING SYSTEM (RRMS) – RISER SCOPE – HULLSIDE UMBILICAL SOLUTION	

6.3 TOP INCLINATION MEASUREMENT

6.3.1 Instantaneous roll and pitch at the top of each rigid riser shall be monitored by an inertial measurement unit (IMU).

6.3.2 The inclination signals shall be filtered by the IMU to reject vibration-induced high-frequency variations. The filtering scheme implemented by the IMU shall be presented for PETROBRAS approval.

Note: the filtering shall be performed by the IMU itself, since it is not possible to perform it as a later processing step (e.g. in the topside acquisition system) due to the low data acquisition frequency.

6.3.3 Since measured angles depend on the alignment of the inertial unit with respect to the riser, measurements shall be transformed to a known reference system according to Annex B: *Rigid Riser Top Angles Calculation*.

6.3.4 IMU maximum permissible errors, for 95% coverage probability, shall be $\pm 0.1^\circ$ for roll and pitch.

6.3.5 The IMU shall reside in a subsea-proof enclosure rated for a minimum depth of 100 m. IMU weight shall not exceed 10 kg in water, in order to be compatible with installation by divers.

6.3.6 An appropriate clamp shall be supplied to firmly attach each IMU to the riser at an appropriate location at steel pup piece aligned with the FBG strain sensor index #1 (see Figure 6). The outer surface of the steel pup piece shall include painted line marking indication of this correct locations for IMU clamp installation at pipe lay vessel.

6.3.7 The IMU shall be installed before the pull-in inside a mechanical protective enclosure (blister), **in order to reduce diver activities and fasten the commissioning phase**. This enclosure shall permit diver access in order to replace IMU sensor and electrical jumper if necessary.

6.3.8 The IMU attached to each rigid riser should communicate with the RDCS by means of RS-485 link. Other options may be proposed and subjected to PETROBRAS approval and shall be compatible with the type and length of specified cabling.

6.3.9 Inside IMU canister shall be provided a triaxial gyroscope in order to measure the heading (**angle accuracy of 0.5°**) and calculate the misalignment of IMU as described on Annex B: *Rigid Riser Top Angles Calculation*. The gyro communication shall also observe item 6.3.11.

6.3.10 The IMU shall be powered by RRMS cabinet with 24 VDC.

6.3.11 The IMU communication to RRMS cabinet shall be:

- Serial RS-485 format;
- NMEA-0183 protocol [13];
- Using up to two of twisted pairs available by topside infrastructure.

6.3.12 RISER CONTRACTOR shall inform the data format (string) used in all kind of communication to IMU.

6.3.13 The Riser Data Collection System (RDCCS) shall be able to edit the mask of datagram received from each IMU sensor. This functionality allow communication with different models of IMU in case of replacement after delivery of RRMS system.

6.3.14 RISER CONTRACTOR shall not provide customized hardware in IMU. All components (or the IMU itself) chosen shall be equipment available off-the-shelf by three manufacturers at least.

6.4 TOP STRAIN MEASUREMENT

6.4.1 Axial tension and bending moments acting at the top of rigid risers selected by PETROBRAS shall be monitored. The requirements presented herein shall apply only to rigid risers supported directly by the FPU.

6.4.2 In order to assess these variables, strain and temperature sensors shall be installed below the riser flexible joint (or stress joint), in a section of pipe devoid of coating, as illustrated in Figure 5.

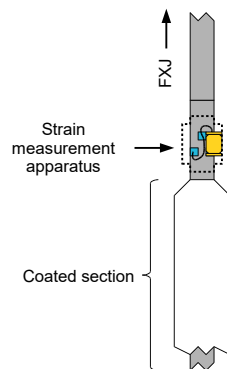

Figure 5 — Illustration of strain monitoring location in rigid risers

6.4.3 Strain and temperature sensors shall be optical Fiber Bragg Grating (FBG) type. Each set of sensors (see item 6.4.4) shall be connected in series in a fiber optical loop and all sensors sets shall be aligned according to the positions presented in Figure 7. Each strain-monitored riser shall have two sensor sets (main and redundant).

6.4.4 Each sensor set (as illustrated in Figure 7) shall have:

- Sixteen (16) FBG sensors, installed around the riser section in two layers (hoop and longitudinal), equally spaced at 45° from each other, to measure hoop and longitudinal stresses at each point around the riser pipe, as illustrated in Figure 6.
- Four (4) body FBG temperature sensors at the strain monitoring location, equally spaced at 90° from each other, to be used for correction of thermal expansion effects.

Note: The FBG array design may be arranged according to the fiber optical channels available by the FPSO CONTRACTOR.

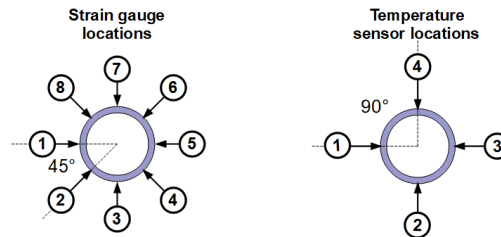

Figure 6 — Illustration of sensor positioning around rigid riser (cross-section view from top)

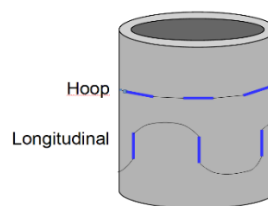



Figure 7 — Schematic view of strain sensing around riser pipe (only active sensors shown)

- 6.4.5** All sensors shall be positioned on the **metal** external surface of the pipe, i.e. they shall not be intrusive to the riser. Moreover, sensors shall not be installed externally to the thermal insulation layer/coating.
- 6.4.6** The FBG strain sensor attachment method and the coating strategy at pup piece shall be subjected to PETROBRAS approval. **The spot-welded strain sensor solution shall not be accepted.**
- 6.4.7** The selected attachment method, including all its components, shall be resistant to the temperature range foreseen in steady state conditions.
- 6.4.8** The riser pipe surface shall undergo preparation in an adequate environment to receive the sensors (e. g. surface cleaning and removal of any contaminants).
- 6.4.9** The temperature and strain sensors in each set shall be numbered starting from index #1 and increasing in the counterclockwise direction, looking from above, as depicted in Figure 6.
- 6.4.10** The maximum permissible error in temperature measurement, for 95% coverage probability, shall be of ± 0.2 °C.
- 6.4.11** Temperature compensation in strain sensors readings shall be implemented for all sensors, in order to eliminate the effects of the thermal expansion of the pipe itself. **The dummy gauge temperature compensation solution shall be accepted, however all the strain variables shall be calculated/stored, i.e., the raw strain sensor readings, seen in Annex C.**

	TECHNICAL SPECIFICATION	Nº I-ET-3000.00-5529-850-PEK-007	REV. A
	JOB	RIGID RISER SYSTEMS	SHEET 14 of 47
	TITLE	RIGID RISER MONITORING SYSTEM (RRMS) – RISER SCOPE – HULLSIDE UMBILICAL SOLUTION	

6.4.12 Strain and temperature sensors shall not be designed for recoverability.

6.4.13 The sensors attached to the riser shall be covered by a protective layer that prevent contact with water and other environmental conditions, and protect pipe section structure (i.e. corrosion) for the riser’s design life. Additionally, mechanical protection shall be provided in order to avoid sensor damage during installation.

6.4.14 The steel pup piece coating shall observe requirements at technical specifications:

- I-ET-0000.00-0000-210-P9U-001 [19] - PIPELINE FIELD JOINT COATING AND FIELD REPAIR OF LINEPIPE COATING
- I-ET-0000.00-0000-431-P9U-001 [20] - WET THERMAL INSULATION FOR FLOWLINES AND RISERS
- I-ET-0000.00-0000-250-P9U-002 [21] - MINIMUM REQUIREMENTS FOR BUOYANCY MODULES FOR FLOWLINES AND SLWRS.

6.4.15 The FBG sensors should be protected by the same mechanical protective enclosure (blister) from IMU sensor (see item 6.3.7). This enclosure shall permit diver access in order to replace optical jumper if needed.

6.4.16 The subsea connection of FBG sensors shall be made by optical jumpers. In these jumpers, on both sides, shall be used optical wet-mate connectors.

6.4.17 The design life of FBG sensors **set** shall be the same of the risers as is for all subsea equipment.

6.4.18 All top strain measurement components of an individual monitoring system supply shall be subjected to PVT type tests after placing the SUPPLIER AFM, including cycling operation in a hyperbaric chamber according to procedures approved by PETROBRAS. The samples used in these tests shall be chosen randomly from those manufactured for the RRMS MONITORING SYSTEM and cannot be reused as part of the RRMS MONITORING SYSTEM equipment after the tests.

6.4.19 A detailed description of the suggested algorithm to compute axial tensions and bending moments at the top of each rigid riser is given in Annex C: *Rigid Riser Stress Calculation Algorithm*. Other algorithms may be proposed and subjected to PETROBRAS approval.

6.4.20 At the algorithm to compute axial tensions and bending moments, it shall be possible to selectively enable/disable the data input from each FBG strain sensor and temperature sensor.

6.4.21 The strain measurement system shall satisfy the following performance requirements:

**TECHNICAL SPECIFICATION**

Nº

I-ET-3000.00-5529-850-PEK-007

REV.

A

JOB

RIGID RISER SYSTEMS

SHEET

15

of

47

TITLE

**RIGID RISER MONITORING SYSTEM (RRMS) –
RISER SCOPE – HULLSIDE UMBILICAL SOLUTION**

- Maximum permissible error for axial tension, for 95% confidence level: ± 80 kN.
- Range: to be defined during execution phase. The range shall be selected as appropriate to properly assess fatigue damage in the riser.
- **SUPPLIER shall present to PETROBRAS technical analysis (with factory testing results) of the calibration degradation over time and the error generated by the influence of the pipe internal pressure in the final strain calibration.**

	TECHNICAL SPECIFICATION	Nº I-ET-3000.00-5529-850-PEK-007	REV. A
	JOB RIGID RISER SYSTEMS	SHEET 16 of 47	
	TITLE	RIGID RISER MONITORING SYSTEM (RRMS) – RISER SCOPE – HULLSIDE UMBILICAL SOLUTION	

6.5 SUBSEA CABLING

- 6.5.1** The monitoring units for each riser shall be connected by means of appropriate (electrical and optical) subsea jumpers.
- 6.5.2** Both subsea jumpers shall be supplied with a protection system designed and developed to protect the fiber optic cores and the electrical conductors against any abrasions and dynamical effects especially in the transition section between lower balcony and riser body.
- 6.5.3** Both subsea jumpers shall be terminated in diver-mate connectors matching the corresponding ones on the FPU side. The connector models shall be defined during project execution through formal consultation with PETROBRAS that will coordinate RISER and FPU CONTRACTOR to provide the same matching models.
- 6.5.4** The electrical subsea jumpers shall have at least 3 TSP with conductors with cross section of 2.5mm² (0.6/1kV rating). The optical subsea jumpers shall have at least 4 fiber cores with standard single mode fibers (ITU-T G.652 or ITU-T G.654 – water blocked).
- 6.5.5** If, by the project schedule, FPU CONTRACTOR has already defined the connector models, PETROBRAS will just inform RISER CONTRACTOR the chosen ones, to be adopted in riser design.
- 6.5.6** The electrical subsea jumper cable shall be terminated in wet-mate connectors to connect at the lower balcony (matching with FPU CONTRACTOR connector) and with the IMU subsea unit (in order to make possible the recovery of only this subsea unit individually). Both wet-mate connectors shall be designed with the following requirements:
- Diver-mate solution;
 - Be 7 (seven) ways electrical pins;
 - Be housing made with stainless steel material (AISI 316L);
 - Be suitable for operation in the foreseen environment;
 - Have a dual barrier solution to protect the electrical connections/pins;
 - Be able to withstand at least 100 connection/disconnection cycles;
 - Be qualified according to API-17F [1] (shall present evidences);
 - Have a design life of at least 25 years.
- 6.5.7** The optical subsea jumper cable shall be terminated in wet-mate connectors to connect at the lower balcony (matching with FPU CONTRACTOR connector) and with FBG

sensors sets. Both wet-mate connectors shall be designed with the following requirements:

- Diver-mate solution;
- Be 4 (four) or more-ways optical fiber cores, with fibers end face Angled Physical Contact (APC);
- Be housing made with stainless steel material (AISI 316L);
- Be suitable for operation in the foreseen environment;
- Have a dual barrier solution to protect the optical connections;
- Be able to withstand at least 100 mates/demates cycles;
- Be qualified according to API-17F [1] (shall present evidences);
- Have a design life of at least 25 years.

6.5.8 Both subsea jumpers shall be supplied with dummy connectors in order to safeguard the wet-mate connectors at any maintenance activity underwater. RISER CONTRACTOR shall also design and supply parking places for these dummy connectors at the monitoring units supporting structures.

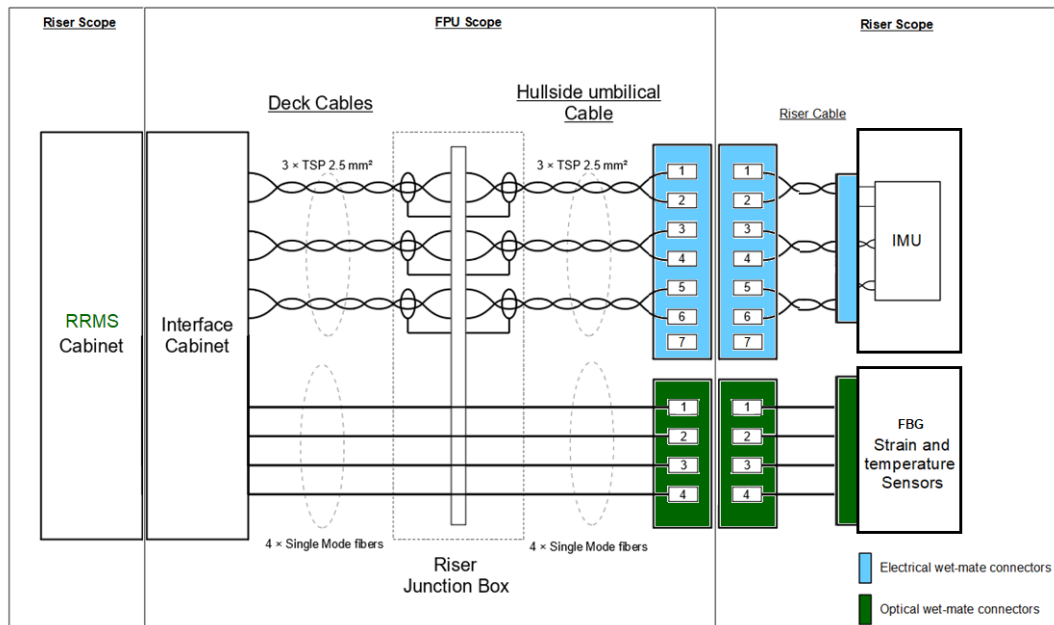



Figure 8 — Connection diagram for rigid riser cabling

6.5.9 The electric and optical subsea jumpers shall be designed considering the connection scheme specified in Figure 8, especially regarding cable run lengths. Information on FPU dimensions and infrastructure shall be obtained in consultation with PETROBRAS.

	TECHNICAL SPECIFICATION		Nº	I-ET-3000.00-5529-850-PEK-007	REV.	A
	JOB	RIGID RISER SYSTEMS			SHEET	18 of 47
	TITLE	RIGID RISER MONITORING SYSTEM (RRMS) – RISER SCOPE – HULLSIDE UMBILICAL SOLUTION				

6.6 SENSORS TEST KIT

- 6.6.1** The RRMS Sensors Test Kit (STK) shall comprise all electrical and optical hardware to easy test and check the IMU and the FBG strain sensors' measurements onshore or offshore (at installation vessel).
- 6.6.2** The RRMS STK shall have a rugged notebook with a Microsoft Windows based solution in order to gather and visualize RRMS sensors data. The STK notebook supply shall include all power and communication cabling.
- 6.6.3** The RRMS STK shall have a transportation test box that shall include inside DC power supply, serial data server, Ethernet switch and FBG interrogator.
- 6.6.4** The RRMS STK notebook shall communicate with STK test box over Ethernet protocol.
- 6.6.5** The RRMS STK test box that shall be designed in other to be able testing two simultaneously full RRMS riser sensors (i.e. inclination + strain data). The RRMS STK test box shall include 2 sets of sensors cabling (electrical and optical) with a minimum of 5 meters long each. These cabling shall be conditioned in IP-67 transportation boxes and all cabling terminations shall have protective structure (e.g. dummy connectors).
- 6.6.6** The RRMS STK test box shall be powered by an external voltage supply operating range from 90-240 VAC (+/- 10%), 50-60 Hz, and supplied including a protective earth conductor with bipolar circuit and surge protectors breakers inside.
- 6.6.7** RISER CONTRACTOR shall inform, during the commissioning, all administrator passwords needed to operate and manage STK equipment.
- 6.6.8** All software shall be provided by RISER CONTRACTOR with its respective license without need of activation after the delivery. It means that PETROBRAS shall not depend on RISER CONTRACTOR (or its SUBSUPPLIER) to reinstall the software in future maintenances. All calibration files and parameters shall be included in the software.

	TECHNICAL SPECIFICATION		Nº	I-ET-3000.00-5529-850-PEK-007	REV.	A
	JOB	RIGID RISER SYSTEMS			SHEET	19 of 47
	TITLE	RIGID RISER MONITORING SYSTEM (RRMS) – RISER SCOPE – HULLSIDE UMBILICAL SOLUTION				

6.7 GENERAL REQUIREMENTS OF TOPSIDE PROCESSING SYSTEM

6.7.1 The FPU processing system shall have a three-layered architecture:

- The Riser Data Collection System (RDCS) shall be responsible for collecting data from the various sensors and positioning system.
- The data server shall concentrate all functionalities related to data storage (SQL, OPC, etc), working as data repository.
- The Supervisory shall act as a supervisory system, serve data to external clients, process acquired data, issue alarms and log access data.

6.7.2 All components in item 6.7.1 shall run in a same physical server, running as independent virtual machines.

6.7.3 RISER CONTRACTOR shall provide a physical server with the minimum requirement as follow:

- Processor: 2x Intel Xeon-G 5220 18-Core (2.20GHz 24.75MB L3 Cache) or superior;
- RAM memory: RAM: 32GB DDR4-2933 or superior;
- 2 hard disk drives (SSD) of at least 1TB each;
- Support to RAID technology (Implemented by disk controller);
- Remote management by dedicated LAN card, able to:
 - Turn on/off equipment
 - Remote diagnosis;
 - KVM;
 - Support SNMP and RSYSLOG
- Redundant power supply;
- Power Supply, Hard Disks and fans hot-swap type;
- Windows Server Standard (one of the last two versions at least);
- Support to VMWare ESXi (the last two versions at least)

6.7.4 RRMS shall not be part of the FPU cause and effect matrix (i.e. shall not be used to trigger emergency shutdowns).

6.7.5 In the case of power loss, the RRMS shall be able to restart automatically without the need for operator intervention.

6.7.6 RISER CONTRACTOR shall inform, during the commissioning, all administrator

passwords needed to operate and manage all equipment.

6.7.7 All software shall be provided by RISER CONTRACTOR with its respective license without need of activation after the delivery. It means that PETROBRAS shall not depend on RISER CONTRACTOR (or its SUBSUPPLIER) to reinstall the software in future maintenances.

6.7.8 The software in virtual machines shall be able to operate in case of backup and restore the entire virtual machine, in a future server replacement.

6.8 RISER DATA COLLECTION SYSTEM (RDCS)

6.8.1 The Riser Data Collection System (RDCS) shall collect data from all the various specified sources and therefore act as a hub for data distribution at the FPU. It shall operate autonomously without any need for operator intervention.

6.8.2 The FBG sensors from section 6.4 shall be connected to FBG interrogators at RRMS cabinet, which shall collect FBG data (strain and temperature) and communicate to RDCS Processing system. RISER CONTRACTOR shall define the number of FBG Interrogators in order to cover all monitored risers from contract and all possible future rigid risers available in the riser balcony.

6.8.3 The FBG interrogators installed inside RRMS Cabinet shall have the following minimum requirements:

- Swept wavelength laser scan frequency: 100 Hz or better (per channel simultaneously);
- Wavelength range: from 1460 to 1620 nm or wider including this range;
- Optical channels: 16 optical channels per interrogator;
- Wavelength accuracy: 2 pm or better;
- Wavelength repeatability: 1 pm or better;
- Dynamic range (peak): 21 dB or better;
- Full spectrum measurement;
- Peak detection functionality (at hardware firmware);
- SC/APC or LC/APC Optical Connectors;
- Ethernet Port;
- Sensing Analysis Software.

6.8.4 The connection between FBG sensors and FBG interrogators shall be made by optical single mode fiber cores (subsea+topside).

	TECHNICAL SPECIFICATION	Nº I-ET-3000.00-5529-850-PEK-007	REV. A
	JOB	RIGID RISER SYSTEMS	SHEET 21 of 47
	TITLE	RIGID RISER MONITORING SYSTEM (RRMS) – RISER SCOPE – HULLSIDE UMBILICAL SOLUTION	

6.8.5 The FBG interrogators shall be powered by RRMS cabinet.

6.8.6 The FBG interrogators shall communicate with the RDCS over Ethernet protocol.

6.8.7 The design life of FBG interrogators is acceptable **up to** 20 years.

6.8.8 All subsea serial data (RS-485) from section 6.3 shall be concentrated in serial servers (Serial to Ethernet) before being forwarded to RDCS. RDCS shall receive serial data by local LAN network **and provide** an individual serial server by type of data: IMU and FPU positioning.

6.8.9 RISER CONTRACTOR shall design the system to receive data from all rigid risers positions of FPU, independent of number of rigid risers of this contract, observing the capacity of serial server, cabinet cabling, termination and RDCS in general. RISER CONTRACTOR shall provide additional serial servers in order to receive data from all possible future rigid risers available in the riser balcony.

6.8.10 The FPU position provided by on-board GPS and AHRS (Attitude and Heading Reference System) shall be retrieved by the RDCS from the POS system (*Positioning and Navigation Systems for Floating Production Unit (FPU)*) as it is broadcast by means of three (3) TIA/EIA-485 connections and/or TIA/EIA-422 connections:

- **GPS NMEA 0183 link:** **GSA, GSV**, GGA and ZDA messages.
- **AHRS TSS1 link:** FPU attitude in TSS1 protocol.
- **AHRS NMEA 0183 link:** HDT message.
- **CUSTOMIZED INPUT:** ASCII message.

6.8.11 RDCS shall be able to receive a customized input of FPU Positioning System. This input will receive ASCII data by serial RS-485/422 and can trigger some settable alarms in RRMS supervisory.

6.8.12 The GPS UTC time provided by the FPU Positioning System shall be used as reference for the timestamps of all acquired data.

6.8.13 Data shall be continuously retrieved from the instrumentation installed on risers. The sampling period shall be 1 second and a timeout event shall be understood as the unsuccessful retrieval of 3 consecutive samples.

6.8.14 Angles measured by top inclination measurements unit (IMU) shall be converted in accordance to Annex B: *Rigid Riser Top Angles Calculation*.

6.8.15 Load and stress calculations for rigid risers should be implemented as described in Annex C: *Rigid Riser Stress Calculation Algorithm*. Other algorithms may be proposed and subjected to PETROBRAS approval.

	TECHNICAL SPECIFICATION	Nº I-ET-3000.00-5529-850-PEK-007	REV. A
	JOB	RIGID RISER SYSTEMS	SHEET 22 of 47
	TITLE	RIGID RISER MONITORING SYSTEM (RRMS) – RISER SCOPE – HULLSIDE UMBILICAL SOLUTION	

6.8.16 Annex A: *OPC Interface Requirements* presents a summary of the variables to be monitored. Additional data shall be acquired as necessary in order to the monitoring system to keep track of the status of every unit and communication channels alike.

6.8.17 The RDCS shall communicate with the Supervisory and Data Server, relaying sensor data. It shall also provide the supervisory with access to all configuration and maintenance interfaces of the various sensors and equipment.

6.9 SUPERVISORY AND DATA SERVER

6.9.1 A Supervisory and Data Server shall communicate with the Riser Data Collection System and act as an interface to human operators and external systems of the monitoring system. The Supervisory and Data Server shall be based on Microsoft Windows.

6.9.2 The use of a well-established integrated supervisory solution able to provide all required functionalities is strongly advised.

6.9.3 Dedicated supervisory screens shall report the value of every monitored variable as they are acquired, along with the status of communication channels and each monitoring unit, including the remaining charge of subsea battery modules. The minimum set of monitoring variables is specified in § A.1.

6.9.4 RISER CONTRACTOR shall design supervisory to receive data from all rigid risers' position in FPU. The system shall be able to receive data from future rigid risers. The system shall permit to set at least the following parameters of each riser:

- Riser data (name, position, function, etc);
- Datagram map from IMU (NMEA);
- Calibration parameters of FBG sensors;
- Source of IMU data (Serial Server IP and port);
- Source of FBG sensor data (FBG interrogator IP and port);

6.9.5 Supervisory system shall permit disable monitoring of rigid risers not installed.

6.9.6 A database system for storage of generated data points shall be included. The data tags for which database storage is mandatory are indicated in § A.1. The design may include storage of additional variables.

6.9.7 The database shall operate on a circular buffer pattern, whereby older records shall gradually be overwritten by newer samples once the database reaches its capacity. Storage space shall be provided as a dedicated RAID 1 array, sized for at least 24

months of logging at the highest possible data sampling rate.

- 6.9.8** The supervisory shall allow for the querying and plotting of historical data for user-selectable intervals. Users shall be able to export data sets to files compatible with Microsoft Excel 2003 or newer.
- 6.9.9** Two categories of password protected user accounts shall be implemented, common and privileged. Access to all functionalities of the supervisory shall be restricted exclusively to authenticated users belonging to one of these categories.
- 6.9.10** Configuration duties, including the management of the various monitoring units and also of the user accounts themselves, shall be restricted to privileged users. All view-only functionalities shall be available to all authenticated users.
- 6.9.11** The supervisory shall keep a log of all accesses, both local and remote, for a minimum of 12 months.
- 6.9.12** The supervisory system shall provide Web Interface (HTTP) access to all screens from within PETROBRAS corporate network. Authenticated users shall be given access to all functionalities just as they are available locally.
- 6.9.13** The Web Interface shall be fully compatible with the latest versions of the Internet Explorer, Mozilla Firefox and Google Chrome browsers, without the aid of any plugins.
- 6.9.14** At least 20 concurrent accesses to the supervisory shall be supported by the Web Interface.
- 6.9.15** The standard Microsoft Windows remote desktop solution shall also be provided to allow remote access to the system from onshore facilities.
- 6.9.16** It shall be possible to selectively disable, in the supervisory screens, the acquisition of each individual strain gauge pair (axial and hoop strain) of the riser top strain measurement.
- 6.9.17** The supervisory system shall generate, display and log alarms for monitored variables. The type of alarm mechanism applicable to each variable is specified in § A.1.
- 6.9.18** Each alarm shall be issued with a descriptive message that allows an operator to clearly identify the condition and its source (i.e. the structure, data tag and/or components involved).
- 6.9.19** The supervisory shall provide the infrastructure to manage and configure alarm limits and to enable/disable each alarm individually. An alarm shall remain active until it is explicitly acknowledged by an operator.
- 6.9.20** “Range”-type alarms shall be implemented with configurable LL/L/H/HH limits for the monitored variable value.

6.9.21 All alarms should include some form of hysteresis mechanism in order to avoid excessive alarm generation when the monitored value is near alarm thresholds.

6.9.22 Alarms shall also be issued for monitoring system failure conditions (housekeeping), including loss of communications to any component and detection of faulty sensors. Refer to item 6.8.13 for details on the definition of *timeout* regarding some of the monitored variables.

6.9.23 Alarms shall be classified in the following severity levels:

▪ **High:**

- LL/HH (low-low/high-high) range alarms.
- “Red” offset diagram alarms.
- Loss or degradation of monitoring system functionality, or conditions which may imminently lead to that. Example: loss of communications with a component/sensor (timeout).

▪ **Medium:**

- L/H (low/high) range alarms.
- “Yellow” offset diagram alarms.
- Conditions which do not cause degradation of monitoring system functionality but may lead to that if unchecked.

▪ **Low:**

- Notifications of changes in system operating modes.
- Any other implementer-defined conditions which do not present an immediate thread to integrity.

6.9.24 Detailed design of the alarm system shall be submitted for PETROBRAS approval prior to implementation.

6.9.25 Real-time data shall be made available for external access through a standardized interface using both the OPC DA (Data Access) and OPC UA (Unified Architecture) protocols. The minimum set of tags to be implemented is specified in Annex A: *OPC Interface Requirements*

6.9.26 The system shall make use of the OPC data quality attributes, including status codes, to signal data health/diagnostic information as prescribed in the relevant sections of the OPC DA and OPC UA specifications.

6.9.27 A historian database system, capable of providing data to the PETROBRAS corporate network through both OPC HDA (Historical Data Access) and OPC UA interfaces, shall

be implemented. The minimum set of tags to be implemented is specified in Annex A: *OPC Interface Requirements*.

6.9.28 Alarms shall be made available for external clients through an OPC UA Alarms & Conditions interface.

6.9.29 The provided interfaces shall be ready for use by external systems from the PETROBRAS corporate network which are allowed through FPU network firewalls.

6.10 RRMS CABINET AND EQUIPMENT

6.10.1 The complete topside processing system shall be supplied by RISER CONTRACTOR as a single stand-alone cabinet, the RRMS Cabinet.

6.10.2 FPU CONTRACTOR shall supply and install one cabinet (named as RRMS Interface Cabinet) in Electrical Module, where shall be terminated all cabling from Risers (Deck Cables), FPU Positioning system and PETROBRAS Corporate Network.

6.10.3 Interface cabinet shall be provided in order to integrate FPU and RISER CONTRACTOR scopes. RRMS Cabinet and Interface cabinet shall be installed side by side;

6.10.4 Interface Cabinet shall be connected to FPU Positioning System (POS) and PETROBRAS corporate network as detailed in table.

Cable Specification	No. of Runs	From/To	Termination	Intended Function
Shielded CAT-6 Ethernet cable	4	Interface Cabinet to FPU PETROBRAS network switch	Standard RJ-45 female patch panel inside Interface Cabinet.	PETROBRAS corporate network
Signal – 4 TSPs 1.5 mm ²	4	Interface Cabinet to FPU Positioning System	SAK Terminals inside Interface Cabinet	FPU Positioning System (POS)

Table 1 — Common topside cabling interfaces

6.10.5 The cabling connections between Interface Cabinet and RRMS cabinet shall be provided/installed by RISER CONTRACTOR;

6.10.6 The cabinets shall be installed in a non-classified, temperature-controlled room allowing frontal and rear access. As a general rule, the RRMS Cabinet shall be

installed in the same electrical panel room as the subsea production control system cabinets (e.g. Master Control Stations). The chosen location shall make it feasible for the cabinet to be installed offshore, i.e. not in a shipyard.

6.10.7 The dimensions of the cabinet shall be 800 mm × 800 mm × 2000 mm (width × depth × height). The cabinet shall have a transparent front door.

6.10.8 Cables shall enter the RRMS Cabinet through the bottom.

6.10.9 Mechanical interfaces of the cabinet for floor mounting shall be agreed during execution phase.

6.10.10 The RRMS cabinet shall be powered by a nominal voltage of 220 VAC (+/- 10%), 50-60 Hz, to be supplied through a cable including a protective earth conductor (with bipolar surge protector). Maximum power demanded by the cabinet shall be limited to 3000 W. It shall be treated as a regular load, i.e. neither essential nor emergency.

6.10.11 The RRMS cabinet shall provide power to all other components of the monitoring system by means of redundant power supplies, each protected by dedicated circuit breakers and surge protectors including short circuit protection. **The RRMS cabinet shall have a managed rack PDUs.**

6.10.12 **RISER CONTRACTOR. shall supply cabinet accessories (circuit breakers, surge protectors, power strips, heat dissipation fans, electrical cabling, network cabling, optical patch cords, etc) according to the detailed design of the RRMS cabinet.**

6.10.13 User interface devices, including keyboard, mouse and monitor, shall be available for local access to the supervisory system. All user interface devices shall be installed at a comfortable height for human users and with proper consideration for ergonomics.

6.10.14 The RRMS cabinet shall include RRMS housekeeping healthy status instrumentation. That monitoring instrumentation shall include, as minimum: RRMS cabinet internal temperature, RRMS cabinet input power electrical supply (volts, watts), IMU sensors power electrical supply (volts, watts), FBG interrogators power electrical supply (volts, watts). RISER CONTRACTOR shall design healthy status with housekeeping monitoring instrumentation and include all these raw data at RRMS OPC map.

6.11 CONNECTION ARCHITECTURE

6.11.1 The interconnection layout is presented in Figure 9, with an example of 4 risers: two in RISER CONTRACTOR scope and another two in future project.

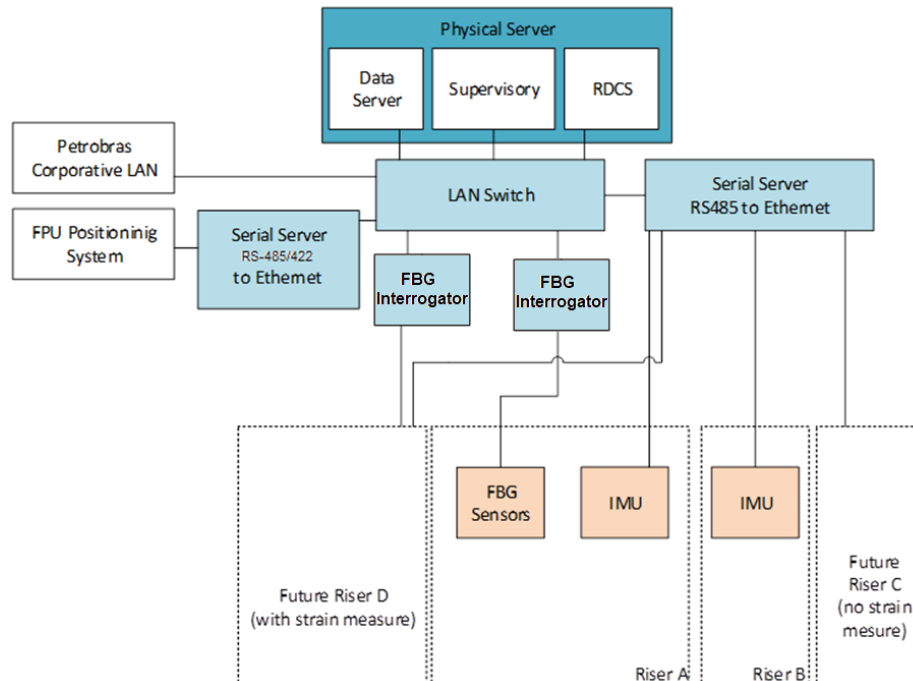

Figure 9 — Processing system interconnection architecture

6.11.2 RISER CONTRACTOR shall provide a network switch that shall connect all LAN equipment.

6.11.3 The network switch shall have the following minimum requirements:

- Gigabit Ethernet ports to accommodate all equipment and servers computers from the RRMS Cabinet.
- Support Spanning Tree Protocols, Virtual Local Area Networks, Link Aggregation, Flow Control, Class of Service, Remote Access, Simple Network Management Protocol, Remote Network Monitoring;
- Rack Mounted;
- Height: 1U.

6.11.4 Any protocol converters and network switches shall be off-the-shelf, industrial-grade components. All physical interfaces/cards shall have added redundancy.

6.11.5 The IP address range used in RRMS Ethernet equipment shall be designated by PETROBRAS during the executive design. **RISER CONTRACTOR shall ask PETROBRAS to inform IP Address range that shall be configured in each equipment.**

6.11.6 All equipment shall be able to be accessed remotely by PETROBRAS LAN network.

6.11.7 The firewalls shall be configured to allow access from the PETROBRAS corporate network to RRMS using the following protocols through any of their standard ports:

- OPC related protocols;
- Windows Remote Desktop services;
- HTTP, HTTPS;
- FTP, FTPS;
- SQL;
- SSH and Telnet.

6.12 FPU INFRA STRUCTURE SCOPE

6.12.1 FPU CONTRACTOR shall provide Riser Junction boxes in order to make the transition between Hullside Umbilical cabling and Deck cabling. One JB shall be used to connect one or more risers. RISER junction boxes shall be installed in the FPU main deck and FPU CONTRACTOR design shall evaluate if may require an intermediate JB close to the upper balcony.

6.12.2 Riser Junction Boxes shall be installed **by FPU CONTRACTOR** in places with easy access, in maximum high of 2 meters and where is dismissed the use of safety harness for high work.

6.12.3 For each monitored rigid riser, FPU CONTRACTOR shall provide the following minimum cabling interfaces between Interface Cabinet and Riser Junction Box.

Cable Specification	No. of Runs	From/To	Termination	Intended Function
Power – 3 TSP 2,5 mm ² 0.6/1 kV rating	1	Interface Cabinet to Riser JB	Connected to corresponding hullside umbilical cable	Power and communication to monitoring equipment
4 single mode Optical fibers	1	Interface Cabinet to Riser JB	Connected to corresponding hullside umbilical cable	Data Acquisition channels to rigid riser monitoring strain sensors

Table 2 — Topside cabling interfaces for rigid risers

6.12.4 Each deck cable meant for a rigid riser shall be connected, in a conductor-by-conductor basis, to the corresponding hullside umbilical cable at a convenient junction box, as shown in Figure 10.

6.12.5 All corresponding shields belonging to each cable (deck vs. subsea) shall also be interconnected at the junction point.

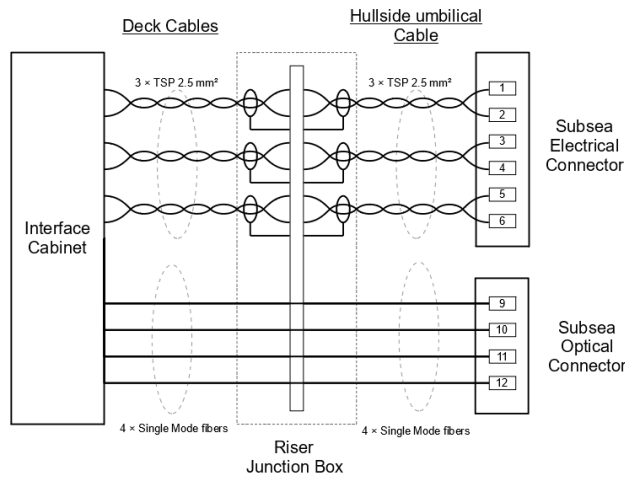

Figure 10 — Connection diagram for rigid riser cabling

6.12.6 Hullside Umbilical Cabling means the cables between Riser Junction Boxes and Diver Mate connectors **to be** supplied and installed by FPU CONTRACTOR at Lower Riser Balcony. This cabling **scope** is part of hullside umbilical provided to attend risers support automation. The Hullside umbilical is detailed in Ref [14].

6.12.7 Wet mate connectors shall be provided on the FPU hull for connecting monitoring units attached to each rigid riser. The connection scheme is illustrated in Figure 11.

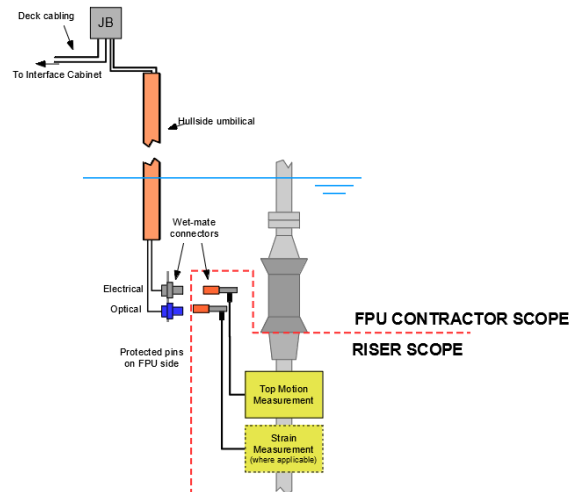

Figure 11 — Rigid riser connection scheme

- 6.12.8** FPU CONTRACTOR shall provide a panel to place wet mate connectors. This panel shall have easy access to divers. This panel shall foresee a structure to tie connector and cables from Riser (RISER CONTRACTOR scope).
- 6.12.9** PETROBRAS shall coordinate the chosen of connector models between FPU and RISER CONTRACTOR.
- 6.12.10** FPU CONTRACTOR shall provide a support to fasten the subsea cable from the riser, close to subsea connector, avoiding mechanical stress in cable and connector.
- 6.12.11** Each FPU connector shall be fitted with a dummy connector for protection from the subsea environment until its corresponding jumper is connected. For cable integrity testing purposes, the electrical dummies shall internally connect each pair of pins with a resistor as specified in Table 3 and the optical dummies shall internally connect each pair of pins with an optical loop (1-2 & 3-4).
- 6.12.12** The body of each subsea connector shall be electrically connected to the FPU cathodic protection system if necessary.
- 6.12.13** Connections between electrical subsea connector pins and hull cable conductors, for all connector types, shall be as specified in Table 3.

Connector Pin Number	Hull Cable Assignment	Dummy Resistance Value
#1	Signal/power cable TSP 1	15 kΩ
#2		
#3	Signal cable TSP 2	22 kΩ
#4		
#5	Signal cable TSP 3	33 kΩ
#6		

Table 3 — Hull connector pin assignment for rigid riser slots (electrical pins)

- 6.12.14** Connections between optical subsea connector pins and hull cable fibers, for all connector types, shall be as specified in Table 4.

Connector Pin Number	Hull Cable Assignment
#1	FBG sensors array loop 1 (main)
#2	
#3	FBG sensors array loop 2 (redundant)
#4	

Table 4 — Hull connector pin assignment for rigid riser slots (optical pins)

- 6.12.15** On the topside, each hull-side subsea cable shall be connected to the corresponding deck cables in the Riser Junction Box.

	TECHNICAL SPECIFICATION	Nº I-ET-3000.00-5529-850-PEK-007	REV. A
	JOB	RIGID RISER SYSTEMS	SHEET 31 of 47
	TITLE	RIGID RISER MONITORING SYSTEM (RRMS) – RISER SCOPE – HULLSIDE UMBILICAL SOLUTION	

7 TESTS, COMMISSIONING REQUIREMENTS AND ASSISTED OPERATION

7.1 QUALIFICATION TESTING

7.1.1 All subsea equipment shall be qualified in accordance with API 17F [1].

7.1.2 Previously qualified equipment may be accepted by PETROBRAS if the provided qualification program has been witnessed/certified by an accredited independent party or by a PETROBRAS representative.

7.1.3 All equipment installed in hazardous areas (explosive atmospheres) shall be certified according to IEC 60079 [7].

7.2 FACTORY ACCEPTANCE TESTING

7.2.1 All subsea equipment (including deliverable spares) shall undergo factory acceptance testing in accordance with API 17F [1]

7.2.2 All sensors shall be calibrated. Calibration reports shall be presented to demonstrate performance requirements are met.

7.2.3 All units shall undergo a full functional test. These tests shall demonstrate correct and stable long-term operation in all possible modes.

7.2.4 Dimensional and electrical/optical checks shall be performed on all units.

7.2.5 Specific requirements are detailed in the next sections.

7.2.6 For Strain Measurement Sensors (included redundancy), the load sensing system shall be calibrated for the specified performance in accordance with ASTM E74 [4]. Other standards or methodologies may be proposed and subjected to PETROBRAS approval.

7.3 SYSTEM INTEGRATION TESTING

7.3.1 Integration tests shall be performed with the purpose of verifying interfaces between components and proper operation of the system as a whole.

7.3.2 All mechanical, electrical, instrumentation and automation interfaces shall be functionally tested.

7.3.3 All system operation modes (and combinations thereof, when multiple components are involved) shall be tested with the aim of ensuring proper long-term, stable operation.

	TECHNICAL SPECIFICATION	Nº I-ET-3000.00-5529-850-PEK-007	REV. A
	JOB	RIGID RISER SYSTEMS	SHEET 32 of 47
	TITLE	RIGID RISER MONITORING SYSTEM (RRMS) – RISER SCOPE – HULLSIDE UMBILICAL SOLUTION	

7.3.4 The system integration test shall be performed with the actual components of the system.

7.3.5 Simulators may be used in place of the FPU positioning system, deck / hull cabling, and umbilical lines. Simulators for cables and umbilical shall be RLC circuits.

7.3.6 **RISER CONTRACTOR shall calculate the final optical losses (ORL and OIL) for the complete installation and shall present it to PETROBRAS. For the SIT, RISER CONTRACTOR shall physically simulate the strain sensor measurement including all calculated optical losses in order to guarantee system functionality on the final installation.**

7.3.7 The proper operation of external data interfaces (OPC UA) shall be attested with a connection to a test computer running client data acquisition software.

7.4 INSTALLATION AND COMMISSIONING REQUIREMENTS

7.4.1 The requirements presented in this section shall be met regarding commissioning activities. Planning of installation and commissioning activities shall be developed and submitted for PETROBRAS approval.

7.4.2 Commissioning is understood, in this context, as the process of placing the system (or parts thereof related to a particular monitored structure) in a fully functional state, without any pending issues.

7.4.3 All equipment shall be tested onshore before deployment at sea. Testing and interventions on equipment during offshore deployment (i.e. on deck of pipelay vessel) shall be avoided, save for emergency occasions or planned in accordance with PETROBRAS using RRMS STK (section 6.6).

7.4.4 The system shall be delivered with all configurable parameters (such as alarms, safe limits and calibration coefficients) preset to correspond to the riser design data.

7.4.5 FPU components shall be installed and commissioned prior to installation of any riser, in order to be ready to receive monitoring data as soon as it becomes available.

7.4.6 The commissioning schedule of monitoring system shall be agreed with PETROBRAS. The base case to be considered is to perform commissioning of monitoring units for each riser shortly after its respective pull-in operation.

	TECHNICAL SPECIFICATION	Nº I-ET-3000.00-5529-850-PEK-007	REV. A
	JOB	RIGID RISER SYSTEMS	SHEET 33 of 47
	TITLE	RIGID RISER MONITORING SYSTEM (RRMS) – RISER SCOPE – HULLSIDE UMBILICAL SOLUTION	

7.5 DIVING INSTALATION

- 7.5.1** The party responsible (DIVING TEAM) for the diving activities described herein shall be defined at project's RRMS material requisition document.
- 7.5.2** DIVING TEAM shall execute diving operations to install monitoring components (i.e. IMUs, clamps and interconnecting subsea cabling, supplied by the RISER CONTRACTOR), if needed, onto rigid risers supported directly by the FPU.
- 7.5.3** DIVING TEAM shall be responsible to supply handling installation infrastructure to execute diving operations, i.e. shackles, slings, master links etc.
- 7.5.4** RISER CONTRACTOR shall be responsible to supply any specific subsea installation accessories, i.e. buoyancy modules, specific clamp installation tools etc.
- 7.5.5** RISER CONTRACTOR shall execute the diving procedures and risk assessments that shall be approved in accordance with PETROBRAS and DIVING TEAM.
- 7.5.6** RISER CONTRACTOR shall provide technical assistance offshore, with a technician with total know how of the diving activities, for diving operations for installation of monitoring units onto rigid risers.

7.6 ASSISTED OPERATION

- 7.6.1** Assisted operation shall be performed in two separate periods. For the length of each period, one technician with thorough knowledge of the system shall be assigned to board the FPU and assist PETROBRAS with initial system operations and configurations to integrate with PETROBRAS Network and integrate with PETROBRAS database (using OPC data).
- 7.6.2** One assisted operation period, with duration of 4 days, shall occur immediately after the first riser is commissioned. If only one riser is in the contracted scope, then this clause does not apply and a single assisted operation period shall be executed in accordance with the next clause.
- 7.6.3** One assisted operation period, with duration of 7 days, shall occur after the last riser is commissioned (end of the installation campaign).

	TECHNICAL SPECIFICATION		Nº	I-ET-3000.00-5529-850-PEK-007	REV.	A
	JOB	RIGID RISER SYSTEMS			SHEET	34 of 47
	TITLE	RIGID RISER MONITORING SYSTEM (RRMS) – RISER SCOPE – HULLSIDE UMBILICAL SOLUTION				

8 DOCUMENTATION REQUIREMENTS

8.1.1 Documentation shall be issued in compliance with agreed standards and formal processes.

8.1.2 All documentation delivered to PETROBRAS shall conform to the following standards:

- N-0381 [17] – format and execution
- N-1710 [18] – identification/coding

8.1.3 Safe operation limits of monitored structures shall also be delivered to PETROBRAS in the form of a document.

8.1.4 The RRMS documentation shall include at least the following:

- Design basis;
- Detailed design documentation covering, among others, equipment, software, cabling and general accessories;
- **Electrical and** mechanical drawings for all individually delivered assemblies;
- Datasheets, manuals and certificates for every equipment/instrument when applicable, covering operation, maintenance and installation guidelines;
- Calibration procedures, reports and certificates for every sensor;
- Equations and calibration curves used for converting raw sensor data into engineering values, along with all coefficients used in conversion, for all sensors;
- Detailed system arrangement, including but not limited to, electrical/optical diagrams, cable layout and equipment interconnection diagrams;
- LAN diagram and Complete descriptions of all communication protocols used between equipment;
- Detailed definition and specification of the alarm system designed for the supervisory system;
- Complete OPC I/O list with all implemented tags;
- As-built drawings, when applicable;
- Detailed installation procedures;
- Detailed procedures for all installation/deployment operations to be performed by third parties, including diving operations to be executed by the DIVING TEAM;
- Detailed test and commissioning procedures and reports;
- System operation and maintenance manuals;
- Training plan.

	TECHNICAL SPECIFICATION	Nº I-ET-3000.00-5529-850-PEK-007	REV. A
	JOB	RIGID RISER SYSTEMS	SHEET 35 of 47
	TITLE	RIGID RISER MONITORING SYSTEM (RRMS) – RISER SCOPE – HULLSIDE UMBILICAL SOLUTION	

9 TRAINING REQUIREMENTS

9.1.1 Training shall be provided to qualify personnel appointed by PETROBRAS to operate and maintain (install, dismantle, replace parts and make adjustments) each system component.

9.1.2 Training shall be performed at PETROBRAS facilities in Rio de Janeiro, Brazil (on-shore). Training courses shall be given for two classes of 10 students (total of 20 students). The two classes shall be scheduled at least 1 month apart, to accommodate for PETROBRAS offshore labor regime. Training course shall be sized for 3 days as a minimum. Lessons shall be taught in Portuguese.

9.1.3 The training program shall cover basic system operation and maintenance aspects. A detailed training program shall be submitted for PETROBRAS approval.

9.1.4 The training program shall cover, at least, the following items:

- Complete description of equipment and system;
- Technical and operational characteristics;
- Operating principles;
- Operational cautions and warnings;
- Operational procedures and routines;
- Preventive maintenance routines;
- Diving operations (subsea equipment retrieval and installation);
- Supervisory system operation;
- Storage and conservation of spare equipment.

10 SCOPE OF SUPPLY & WORK

10.1 GENERAL TOPOLOGY

10.1.1 The General Topology in Figure 12 summarizes the supply scope division between FPU CONTRACTOR and RISER CONTRACTOR.

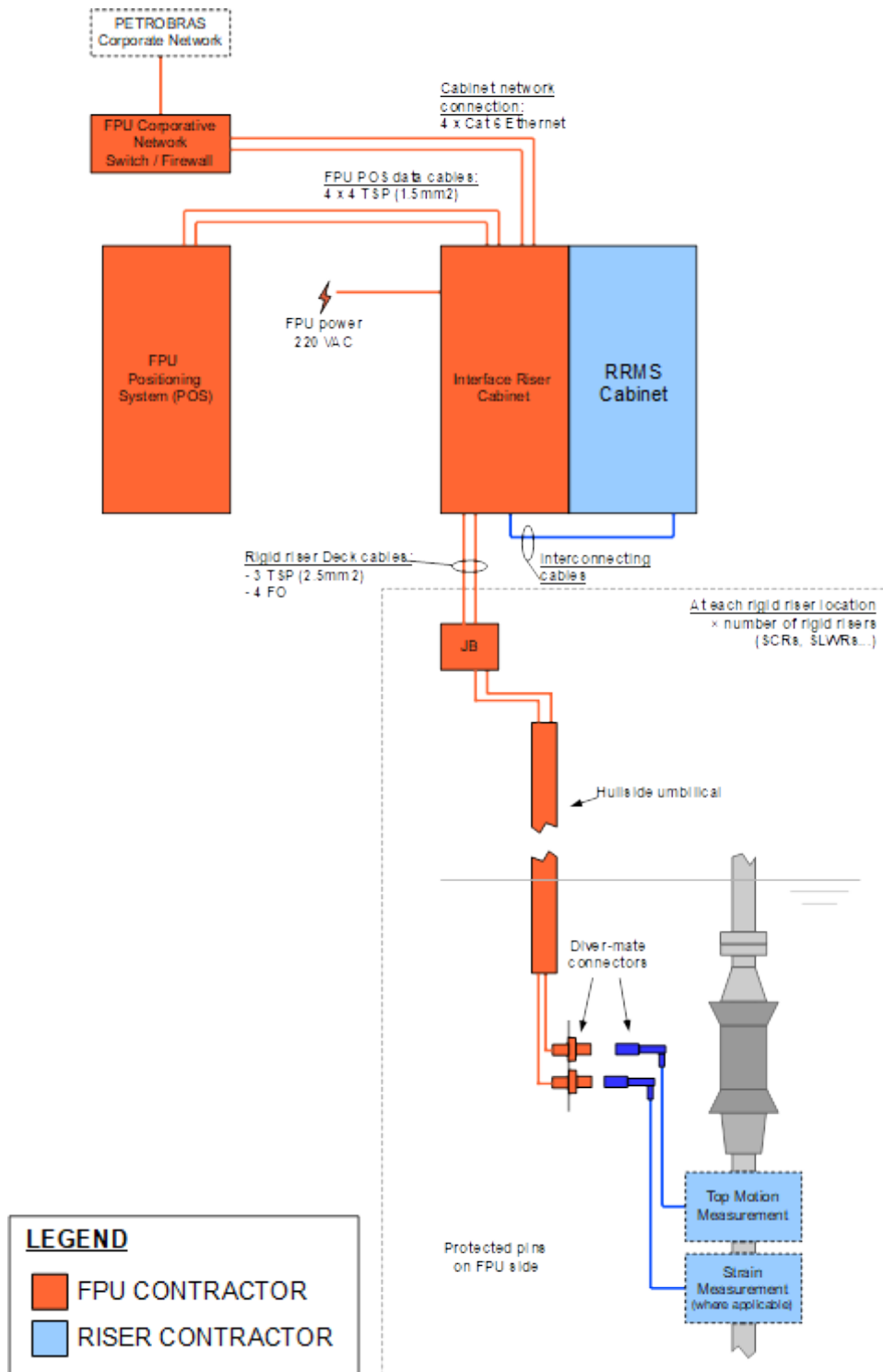

Figure 12 — Scope of supply – RRMS System

10.1.2 The General Topology in Figure 13 summarizes the installation scope division between FPU CONTRACTOR, RISER CONTRACTOR and DIVING TEAM.

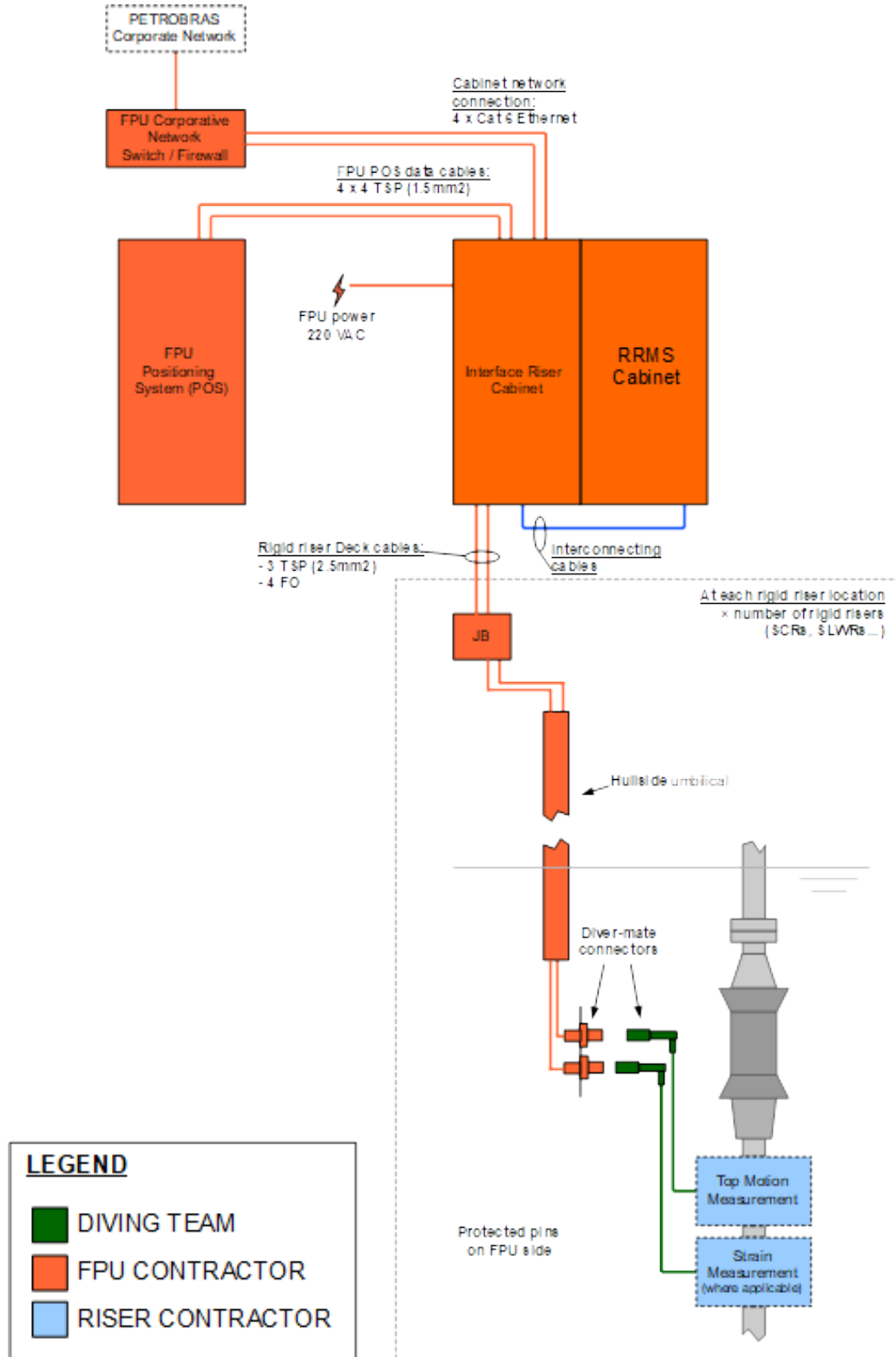



Figure 13 — Scope of installation – RRMS System

	TECHNICAL SPECIFICATION	Nº I-ET-3000.00-5529-850-PEK-007	REV. A
	JOB	RIGID RISER SYSTEMS	SHEET 38 of 47
	TITLE	RIGID RISER MONITORING SYSTEM (RRMS) – RISER SCOPE – HULLSIDE UMBILICAL SOLUTION	

10.2 RISER CONTRACTOR

10.2.1 Design, supply and install the topside processing system as described in section 6.6.

10.2.2 Execute fabrication, qualification, testing and calibration tasks in accordance with the requirements presented in section 7. Any required simulators shall also be provided by RISER CONTRACTOR.

10.2.3 Execute installation and commissioning as described under section 7.4. RISER CONTRACTOR shall provide all tools, accessories and consumables required for these activities.

10.2.4 Provide assisted operation as described under section 7.6.

10.2.5 Provide documentation as described under section 8.

10.2.6 Provide training as described under section 9.

10.2.7 For each rigid riser: execute design, supply and installation scope of all components described in sections 6.3 to 6.6 and associated components (clamps, blister etc) onto rigid risers.

10.2.8 Design, supply and install the Subsea Cabling, as described in section 6.5.

10.2.9 Define, supply and install any necessary interconnecting cabling between the Interface Cabinet and the RRMS Cabinet Topside system according to requirements as described in sections 6.7 to 6.12.

10.2.10 Provide assistance, with an offshore technician, for diver operations for installation of monitoring units onto rigid risers and other described supply scopes as informed in section 7.5.

10.2.11 Supply the following spare units (conditioned in IP-67 transportation boxes) related to rigid risers:

- 2 × rigid riser IMUs with dummy connectors;
- 2 × IMU clamps;
- 2 × electrical jumpers with dummy connectors.
- 1 x optical jumper with dummy connectors;
- 1 x set of optical dummy connectors for “strain and temperature sensors” wet-mate connector;
- 1 x Optical test cable with FBG array mounted in a test box for topside testing.

10.2.12 Spare units shall be identical to the items they replace and undergo the same fabrication, calibration and testing. Spares shall be supplied in packaging proper for long-term storage.



10.3 FPU CONTRACTOR

- 10.3.1** Provide continuous transmission of FPU positioning system data to the riser monitoring system, including cable connections to the FPU POS cabinet.
- 10.3.2** Provide space and facilities (infrastructure) for the RRMS Cabinet.
- 10.3.3** Provide a network connection to the RRMS Cabinet. This shall include configuration of firewalls and allocation of network addresses.
- 10.3.4** Design, supply and install FPU provisions for each rigid riser.
- 10.3.5** Supply and install deck cabling, including terminations.
- 10.3.6** Provide connections between deck cables and hull/subsea cables for rigid risers.
- 10.3.7** Provide assistance to all activities to be performed by the RISER CONTRACTOR aboard the FPU, including crane operation and transportation of loads (cabinets, junction boxes, etc.) and issuance of work permits when needed.
- 10.3.8** Provide documentation from the FPU side with all information needed for the design of the monitoring system, including but not limited to: cabling information, wiring diagrams, area classification, mechanical and electrical interfaces.

10.4 DIVING TEAM

- 10.4.1** DIVING TEAM shall provide activities with scope of supply as described in section 7.5.

	TECHNICAL SPECIFICATION		Nº	I-ET-3000.00-5529-850-PEK-007	REV.	A
	JOB	RIGID RISER SYSTEMS			SHEET	40 of 47
	TITLE	RIGID RISER MONITORING SYSTEM (RRMS) – RISER SCOPE – HULLSIDE UMBILICAL SOLUTION				

ANNEX A: OPC INTERFACE REQUIREMENTS

A.1 Data Tags

A.1.1 Table 1 presents the minimum set of standard data tags that shall be logged by the historian data base (HDB) and published through the OPC UA Data Access (for real-time data) and Historical Access (for historical data) interfaces.

A.1.2 Additional tags may be included as required.

A.1.3 Placeholders for indices in variable tags (e.g. lower-case n and i) shall be substituted for the respective numbers, formatted in decimal base with no leading zeroes (e.g. 1, 2, 3, ...).

Tag	Data Type	Description	Unit	Alarm Type	OPC Alarm Source	Logged in HDB
RRMS_INTERF_REV	8-bit integer	RRMS interface revision (constant) Must be 2 for this version	N/A	–	–	–
NUM_RIG	8-bit integer	Number of monitored rigid risers Valid indices (n) for rigid riser data tags (RIG_n_xxx) shall be in the range 1..NUM_RIG	N/A	–	–	–
FPU_EASTING	32-bit floating-point	FPU absolute easting, as supplied by POS system	m	–	–	Yes
FPU_NORTHING	32-bit floating-point	FPU absolute northing, as supplied by POS system	m	–	–	Yes
FPU_ROLL	32-bit floating-point	FPU roll angle, as supplied by POS system	°	–	–	Yes
FPU_PITCH	32-bit floating-point	FPU pitch angle, as supplied by POS system	°	–	–	Yes
FPU_HEADING	32-bit floating-point	FPU heading with respect to true north, as supplied by POS system	°	–	–	Yes
RIG_n_NAME	String	Rigid riser n descriptive name	N/A	–	–	–
RIG_n_ROLL	32-bit floating-point	Rigid riser n filtered top roll angle at reference frame	°	Range	–	Yes
RIG_n_PITCH	32-bit floating-point	Rigid riser n filtered top pitch angle at reference frame	°	Range	–	Yes
RIG_n_STRAIN_MON	Boolean	Whether strain monitoring is implemented for rigid riser i	N/A	–	–	–
RIG_n_NUM_TEMP ⁽¹⁾	8-bit integer	Rigid riser n number of pipe temperature sensors	N/A	–	–	–
RIG_n_TEMP_i ⁽¹⁾	32-bit floating-point	Rigid riser n pipe temperature measurement i $i = 1..RIG_n_NUM_TEMP$	°C	Range	–	Yes
RIG_n_NUM_STRAIN ⁽¹⁾	8-bit integer	Rigid riser n number of longitudinal/hoop strain sensors	N/A	Range	–	–
RIG_n_RAW_LONG_STRAIN_i(1)	32-bit integer	Rigid riser n raw quantized (ADAC) longitudinal strain value	–	–	–	Yes
RIG_n_RAW_HOOP_STRAIN_i(1)	32-bit integer	Rigid riser n raw quantized (ADAC) hoop strain value	–	–	–	Yes
RIG_n_LONG_STRAIN_i(1)	32-bit floating-point	Rigid riser n raw longitudinal strain measurement i $i = 1..RIG_n_NUM_STRAIN$	µstrain	Range	"RIG_n"	Yes
RIG_n_HOOP_STRAIN_i(1)	32-bit floating-point	Rigid riser n raw hoop strain measurement i $i = 1..RIG_n_NUM_STRAIN$	µstrain	Range	"RIG_n"	Yes
RIG_n_AXIAL_STRESS(1)	32-bit floating-point	Rigid riser n overall axial stress calculated from pipe model.	kN/m ²	Range	–	Yes
RIG_n_HOOP_STRESS(1)	32-bit floating-point	Rigid riser n mean hoop stress calculated from pipe model.	kN/m ²	Range	–	Yes
RIG_n_MAX_BENDING_STRESS(1)	32-bit floating-point	Rigid riser n maximum bending stress calculated from pipe model.	kN/m ²	Range	–	Yes
RIG_n_AXIAL_TENSION(1)	32-bit floating-point	Rigid riser n axial tension calculated from pipe model.	kN	Range	–	Yes
RIG_n_BENDING_MOMENT(1)	32-bit floating-point	Rigid riser n bending moment calculated from pipe model.	kN·m	Range	–	Yes
RIG_n_BENDING_DIR(1)	32-bit floating-point	Rigid riser n bending direction Counter-clockwise from strain sensing position #1.	°	Range	–	Yes

Note:

(1) Applicable for strain-monitored rigid risers only, as indicated by tag RIG_n_STRAIN_MON.

Table 1 — Standard data tags

ANNEX B: RIGID RISER TOP ANGLES CALCULATION

B.1 Top inclination angles shall be reported in the order yaw-pitch-roll, that is, extrinsic rotations around axes z , y and x in that order. For each riser, the reference frame shall be defined as follows (see Figure B1).

- The z axis shall be normal to the horizontal plane, pointing upwards.
- The y axis shall be normal to the plane of the riser catenary, parallel to the horizontal plane.
- The x axis shall be contained in the plane of the riser catenary, parallel to the horizontal plane.
- The directions of axes x , y and z , shall be chosen to satisfy *the right-hand rule*.

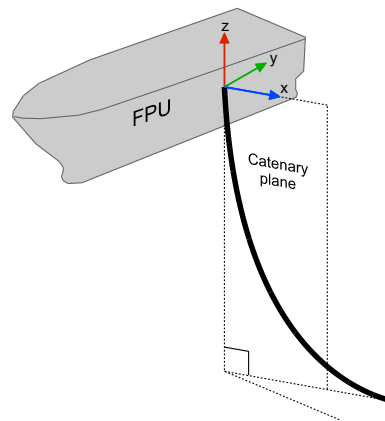

Figure B1 — Illustration of coordinate system for rigid riser top angle calculation

B.2 Corrections shall be carried out to compensate for the misalignment of the IMU around the riser (see Figure B2) so that pitch and roll angles are measured in the reference frame defined in B.1.

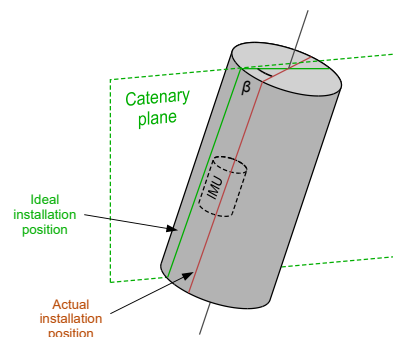

Figure B2 — Illustration of IMU misalignment with respect to rigid riser catenary plane

B.3 In order to measure the angle of misalignment (β) for each IMU, the triaxial gyroscope heading data (item 6.3.9) shall be used to measure the clamp misalignment in relation to the riser catenary final azimuth.



TECHNICAL SPECIFICATION	Nº	I-ET-3000.00-5529-850-PEK-007	REV.	A
JOB	RIGID RISER SYSTEMS		SHEET	42 of 47
TITLE	RIGID RISER MONITORING SYSTEM (RRMS) – RISER SCOPE – HULLSIDE UMBILICAL SOLUTION			

B.4 All necessary calculations for angle corrections of inclination measurements from IMU, given the determined misalignment angle for each riser, shall be implemented in the RDGS. RISER CONTRACTOR shall present the calculations used for angle corrections for PETROBRAS approval

ANNEX C: RIGID RISER STRESS CALCULATION ALGORITHM

This annex presents the desired algorithm and procedure for calculating strains, stresses and tensions on rigid risers.

C.1 Requirements

- C.1.1 All computations shall be performed with sufficient precision as needed to obtain the specified accuracy.
- C.1.2 Output quantities shall be presented through the standardized OPC interface in the prescribed engineering units.

C.2 Inputs

C.2.1 The algorithm takes the following input variables, which will generally be different for each riser:

- N_{sens} : number of longitudinal and hoop strain sensors around riser pipe
- $\varepsilon_{\ell i}$: longitudinal strain sensor i reading; $i = 1, 2, \dots, N_{sens}$
- ε_{hi} : hoop strain sensor i reading; $i = 1, 2, \dots, N_{sens}$
- D : pipe outer diameter
- t : pipe wall thickness
- T : pipe temperature
- T_0 : reference temperature at which pipe dimensions (D , t) are taken
- E : material bulk modulus (material property)
- ν : Poisson coefficient (material property)
- α : thermal dilation coefficient (material property)

C.3 Algorithm Steps

C.3.1 The algorithm steps are summarized next. The description given is for calculations to be performed for a single riser (whose index is denoted by n). Figures are merely illustrative.

1. Raw longitudinal strain readings ($\varepsilon_{\ell i, raw}$) from each sensor around the riser pipe shall be acquired and properly converted using stored calibration data.

The individual raw strain readings $\varepsilon_{\ell i, raw}$ shall be output as data tags RIG_n_LONG_STRAIN_i.

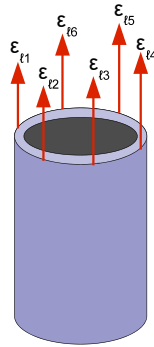

Figure B3 — Individual longitudinal strain measurements around riser pipe

- Raw hoop strain readings ($\varepsilon_{hi,raw}$) from each sensor (strain gauge) around the riser pipe shall be acquired and properly converted using stored calibration data.

The individual raw strain readings $\varepsilon_{hi,raw}$ shall be output as data tags RIG_n_HOOP_STRAIN_i.

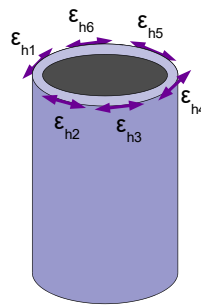

Figure B4 — Illustration of riser hoop strain measurements

- The strain reading compensated for thermal dilation effects shall be computed for each sensor:

$$\varepsilon_{\ell i} = \varepsilon_{\ell i,raw} - \alpha(T - T_0)$$

$$\varepsilon_{hi} = \varepsilon_{hi,raw} - \alpha(T - T_0)$$

- The radial strain shall be computed at each point:

$$\varepsilon_{ri} = \frac{\nu}{\nu - 1} (\varepsilon_{\ell i} + \varepsilon_{hi})$$

- Longitudinal and hoop stresses shall be calculated as:

$$\sigma_{\ell i} = \frac{E}{(1 + \nu)(1 - 2\nu)} [(1 - \nu)\varepsilon_{\ell i} + \nu(\varepsilon_{hi} + \varepsilon_{ri})]$$

$$\sigma_{hi} = \frac{E}{(1 + \nu)(1 - 2\nu)} [(1 - \nu)\varepsilon_{hi} + \nu(\varepsilon_{\ell i} + \varepsilon_{ri})]$$

- A plane-fit algorithm shall be applied to the longitudinal stress data.

The goal is to obtain a least-squares plane fit, i.e. minimize

$$\sum_{i=1}^{N_{\ell}} (\sigma_{\ell i} - \sigma_{\text{fit}}(x_i, y_i))^2$$

Where $\sigma_{\text{fit}}(x, y) = a + bx + cy$ is the plane fit function at point (x, y) .

Let matrix M be defined as

$$M = \begin{bmatrix} 1 & x_1 & y_1 \\ 1 & x_2 & y_2 \\ \vdots & \vdots & \vdots \\ 1 & x_{N_{\ell}} & y_{N_{\ell}} \end{bmatrix}$$

Where x_i and y_i are the positions of the strain sensors installed around the riser:

$$\phi_{\ell i} = \frac{2\pi(i-1)}{N_{\ell}}$$

$$x_i = R \cos(\phi_{\ell i})$$

$$y_i = R \sin(\phi_{\ell i})$$

The coefficients of the plane fit function, a , b and c , shall be computed as follows:

$$\begin{bmatrix} a \\ b \\ c \end{bmatrix} = M^{\dagger} \begin{bmatrix} \sigma_{\ell 1} \\ \sigma_{\ell 2} \\ \vdots \\ \sigma_{\ell N_{\text{sens}}} \end{bmatrix}$$

Where the operator $[]^{\dagger}$ denotes the Moore–Penrose pseudoinverse and is mathematically equivalent to $(M^T M)^{-1} M^T$, the operator $[]^T$ denotes matrix transposition and the operator $[]^{-1}$ denotes matrix inversion.

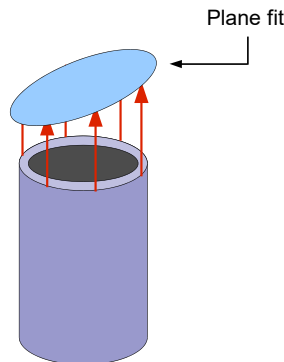

Figure B5 — Illustration of plane fit over longitudinal stress measurements

7. The estimated longitudinal stress distribution around the pipe $\sigma_{\text{fit}}(\phi)$ (where ϕ is the azimuth) resulting from application of the plane fit shall be decomposed into:
 - The overall axial stress, σ_a , which represents the strain induced by pure axial tensioning of the pipe, and shall be computed as:

$$\sigma_a = a$$

The quantity σ_a shall be output as data tag RIG_n_AXIAL_STRESS.

- A bending stress component, which represents the superimposed effect of pipe bending. The output maximum bending strain, σ_b , shall be reported as the maximum value of the bending strain around the pipe, and shall be computed as

$$\sigma_b = R\sqrt{b^2 + c^2}$$

The quantity σ_b shall be output as data tag RIG_n_MAX_BENDING_STRESS.

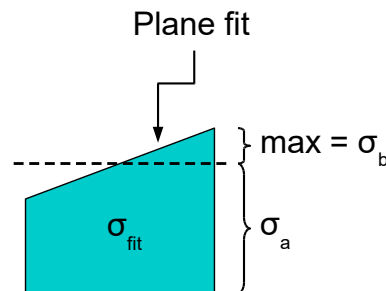

Figure B6 — Illustration of longitudinal stress profile (side view)

8. The overall hoop stress σ_h shall be computed as the mean of the individual hoop stress readings:

$$\sigma_h = \frac{1}{N_{\text{sens}}} \sum_{i=1}^{N_{\text{sens}}} \sigma_{hi}$$

The quantity σ_h shall be output as data tag RIG_n_HOOP_STRESS.

9. From the fit plane, the bending plane azimuth angle θ_b shall be computed as follows:

$$\theta_b = \text{atan2}(c, b) \quad (\text{see note 1})$$

The direction θ_b points away from the center of curvature of the pipe at the monitored section, and shall be measured in the counter-clockwise direction from the position of strain sensor pair #1, as illustrated in Figure B7.

¹ atan2(x, y) is formally defined as:

$$\text{atan2}(y, x) = \begin{cases} \arctan\left(\frac{y}{x}\right) & x > 0 \\ \arctan\left(\frac{y}{x}\right) + \pi & y \geq 0, x < 0 \\ \arctan\left(\frac{y}{x}\right) - \pi & y < 0, x < 0 \\ +\frac{\pi}{2} & y > 0, x = 0 \\ -\frac{\pi}{2} & y < 0, x = 0 \\ \text{undefined} & y = 0, x = 0 \end{cases}$$

The quantity θ_b shall be converted to degrees (in the range $-180^\circ < \theta_b \leq 180^\circ$) and output as data tag RIG_n_BENDING_DIR.

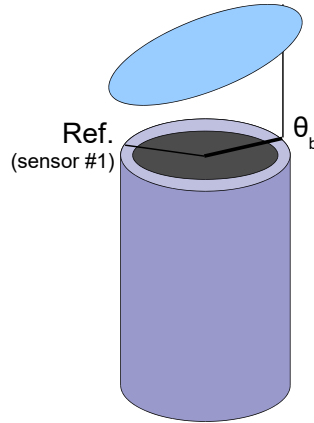

Figure B7 — Illustration of riser bending direction

10. From the calculated stresses, the overall axial tension F_a and bending moment M_b shall be computed:

$$F_a = \sigma_a \pi (Dt - t^2)$$

$$M_b = \frac{2I\sigma_b}{D}$$

where $I = \frac{\pi}{64} (D^4 - (D - 2t)^4)$ is the moment of inertia of the pipe around a perpendicular axis.

The quantities F_a and M_b shall be output as data tags RIG_n_AXIAL_TENSION and RIG_n_BENDING_MOMENT respectively.